

A Level Physics

Summer Transition Work Pack



This pack contains activities and resources to prepare you to start the A level Physics course.

Complete it over the Summer Holidays to ensure you are ready to start in September.

Before September you **must** purchase the course text books:

A Level Physics for OCR A Student Book by Graham Bone,
Nigel Saunders, Gurinder Chadha [[Amazon link](#)]

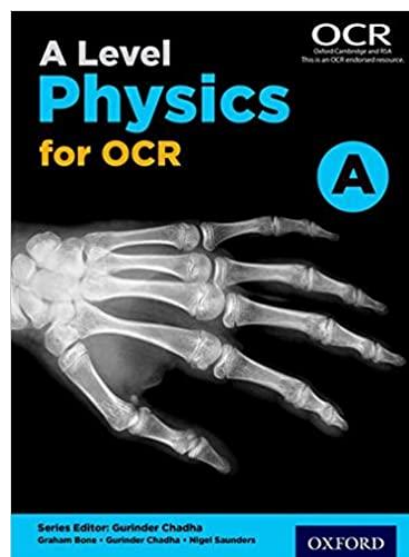

CGP A-Level Physics: OCR A - Complete Revision & Practice
[[Amazon link](#)]

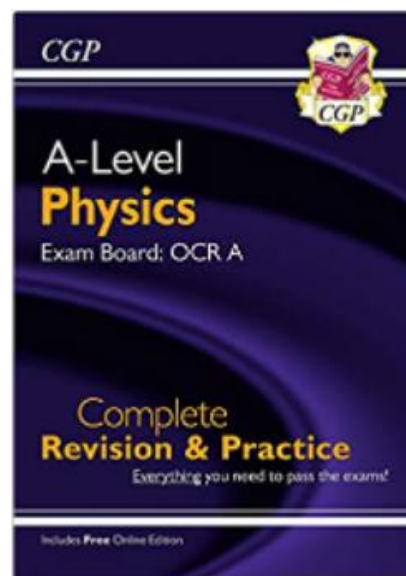

You may also wish to purchase the CGP A-Level Physics: OCR
A Exam Practice Workbook [[Amazon link](#)]

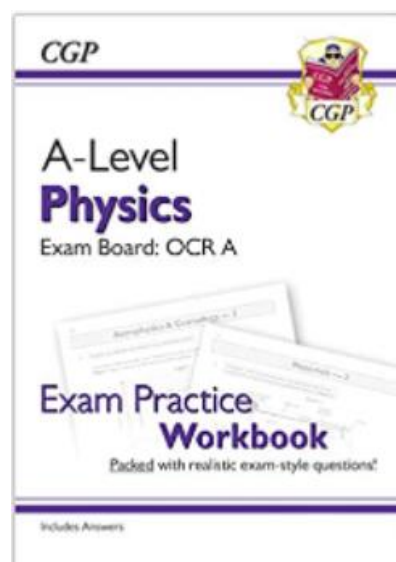

Task 0: Prepare for Baseline Test

You will sit a baseline test in the first couple of weeks. This will cover GCSE content, and you will need to achieve a certain score in order to continue on the A-level.

Task 1: Research

Choose one of the following topics to research and make a 1-page summary sheet using Cornell notes: <http://coe.jmu.edu/learningtoolbox/cornellnotes.html>

This must be presented NEATLY.

Topic 1: Dark Matter

What is dark matter? What is the evidence for dark matter and what are the likeliest candidates for dark matter?

Topic 2: Gravitational Waves

Research in to gravitational waves and the research centre LIGO. What is LIGO and how does it work to detect gravitational waves?

Topic 3: Metallic Hydrogen

Research the elusive metallic hydrogen. Described as the 'holy grail' of science, what is metallic Hydrogen and what would the properties of metallic Hydrogen be?

Topic 4: Fusion reactors

Investigate what fusion is and research ITER. This is the world's largest fusion experiment currently being built in France.

Task 2

Q1 Complete the following table:

Unit prefix	Meaning
k (kilo)	x 1000
	X 0.000001
M (mega)	
n (nano)	

[3]

Q2

a) Write the following numbers into standard form.

i. 0.012

ii. 120000

iii. 0.00000012

[3]

b) Complete the following calculations and right your answers to an appropriate number of significant figures.

i. 2.1×0.15

ii. $0.345 \div 0.114$

[4]

Q3 Re-arrange the following equations to make R the subject of the equation.

a) $Q = WERTY$

b) $Q^2 = WR^2$

c) $Q = W - RT^2$

[3]

Q4 Name the 3 particles (from GCSE) that make up an atom.

..... [1]

a) Which one of the above particles is not found in the nucleus of an atom?

..... [1]

b) Which of the above particles will be found in varying quantities in the nuclei of isotopes of the same element?

.....[1]

Q5

a) Complete the following table

Voltage (V)	Current (A)		
	Repeat 1	Repeat 2	Average
2	0.23	0.26	0.25
4	0.46	0.53	
6	0.69	0.78	0.74
8	0.92	1.04	0.98
10	1.15	1.30	1.23

[3] Q6

a) Use a piece of graph paper to plot a graph of Current (x-axis) against Voltage (y-axis) drawing a line of best fit through your data points. (You may plot a graph on excel <https://www.youtube.com/watch?v=3PwVWX28dEE> will show you how)

[4]

b) Find the gradient of your line of best fit

[3]

- c) Calculate the **average** acceleration in the first 20 seconds.

[2]

Q8

- a) Draw a circuit diagram to show how the resistance of a filament bulb could be measured using an ammeter and a voltmeter.

[2]

- b) Look at the circuit diagram below. All of the resistors are identical.

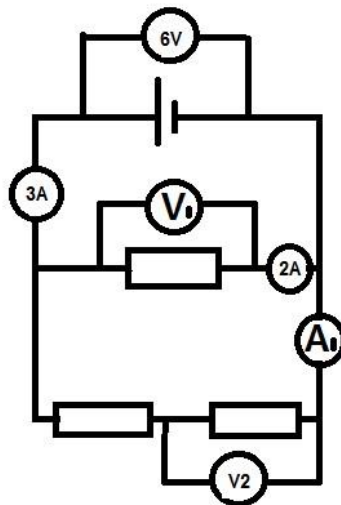

Write the missing values of current and potential difference:

V₁ =

V₂ =

A₁ =

[3]

Q9 The diagram below shows a diagram of 3 complete longitudinal wave oscillations on a slinky:

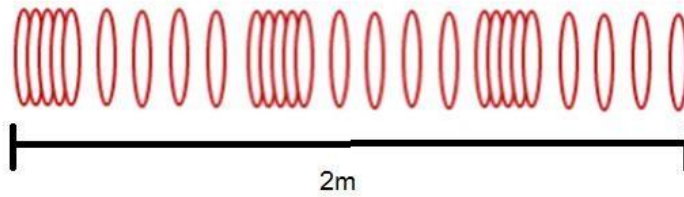

a) State the wavelength of the wave shown

..... [1]
b) Label a complete wavelength on the diagram above with the correct symbol used for wavelength in GCSE and A Level Physics

[1]

c) If the above wave had a frequency of 5Hz how long would it take an individual hoop to complete 1 full oscillation? [1]

d) Calculate the speed of the wave

$$\mathbf{wavespeed = frequency \times wavelength}$$

Wave speed = _____ Unit _____ [2]

Optional task – book recommendations

Human Universe by Brian Cox and Andrew Cohen

Human Universe tackles some of the greatest questions that humans have asked to try and understand the very nature of ourselves and the Universe in which we live.

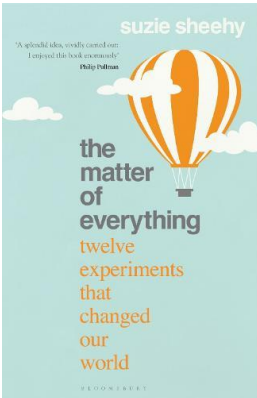
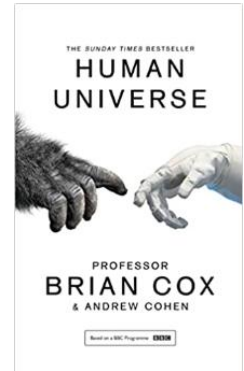

The Matter of Everything: Twelve Experiments that Changed Our World by Suzie Sheehy

From x-rays to smartphones, accelerator physicist Sheehy recounts twelve twentieth-century experiments that fundamentally altered our conception of the world in this highly entertaining and accessible volume.

How To by Randall Munroe

A collection of heroically overcomplicated solutions to everyday issues by an ex-NASA engineer.

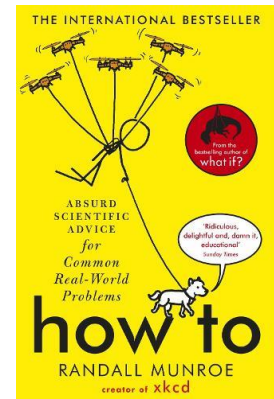

The End of Everything (Astrophysically Speaking) by Katie Mack

Guiding us through the most mesmerising theories about cosmology and quantum mechanics, astrophysicist Katie Mack charts five alternative scenarios of how our universe could cease to exist.

15 Million Degrees: A Journey to the Centre of the Sun by Lucie Green

Discover how the Sun works (including what it sounds like), the latest research in solar physics and how a solar storm could threaten everything we know.

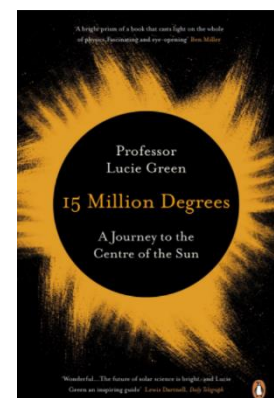

Optional task – film recommendations

Primer (2004)

American independent psychological science fiction film about the accidental discovery of time travel. (Dr Carlyle's top pick)

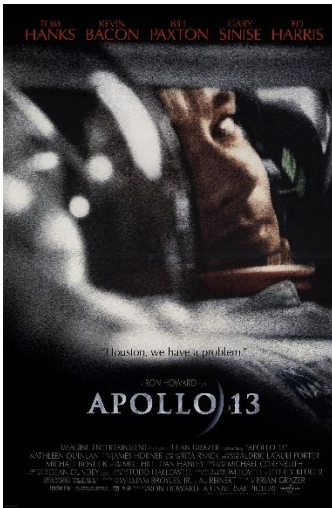

Apollo 13 (1995)

Based on a true story; nominated for nine academy awards; most technically accurate film because it was executed by NASA engineers and actors took a crash course in physics.

Hidden Figures (2016)

The true story of a team of female African-American mathematicians who served a vital role in NASA during the early years of the U.S. space program.



Lo and Behold, Reveries of the Connected World (2016)

Filmmaker Werner Herzog examines the ways in which the Internet has impacted human interaction, and the ways it will continue to impact contemporary society.